

S2S SERIES

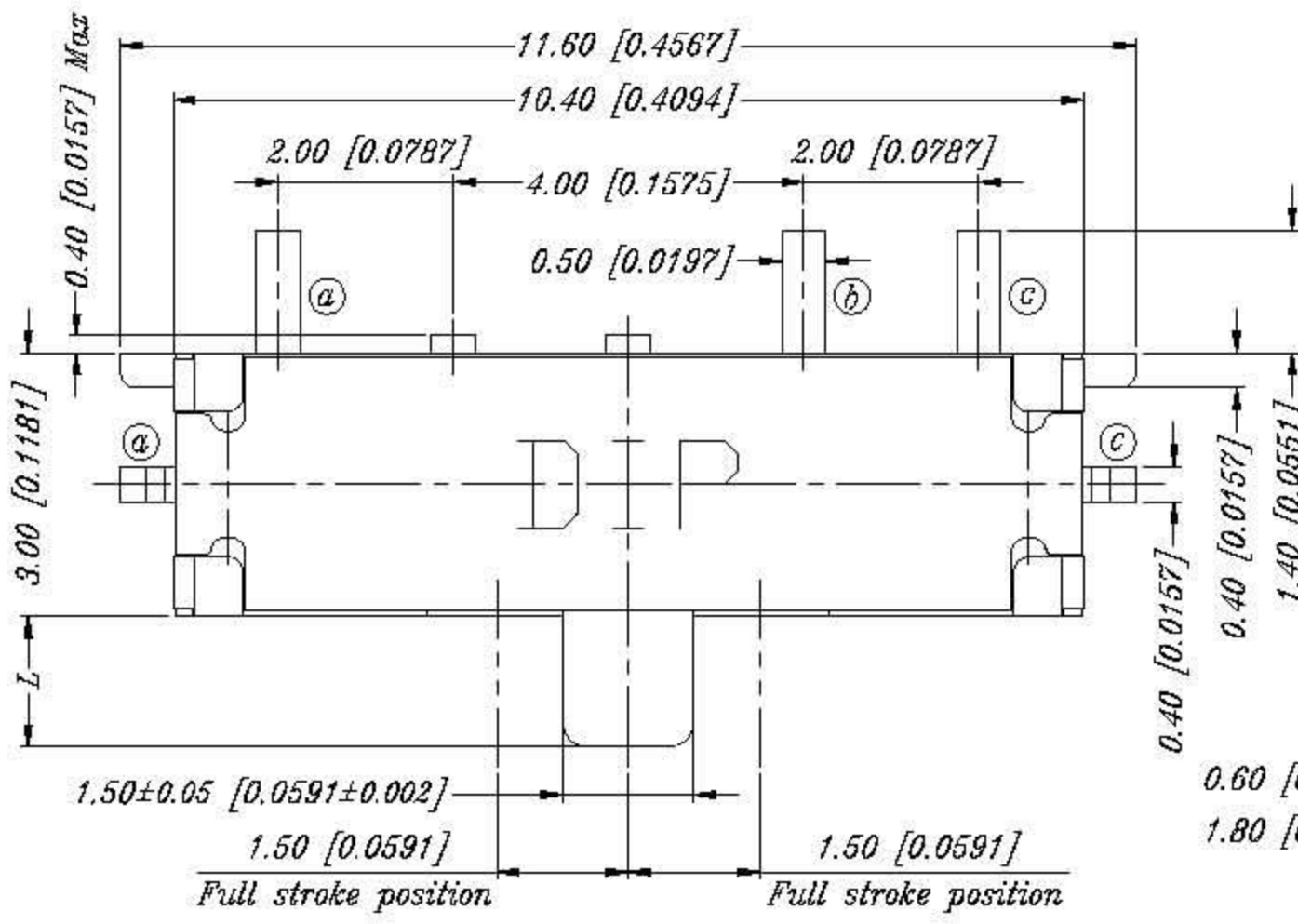

DIMENSION

S2S-AF



PART NO	L
S2S-A15F	1.50 [0.0591]
S2S-A25F	2.50 [0.0984]

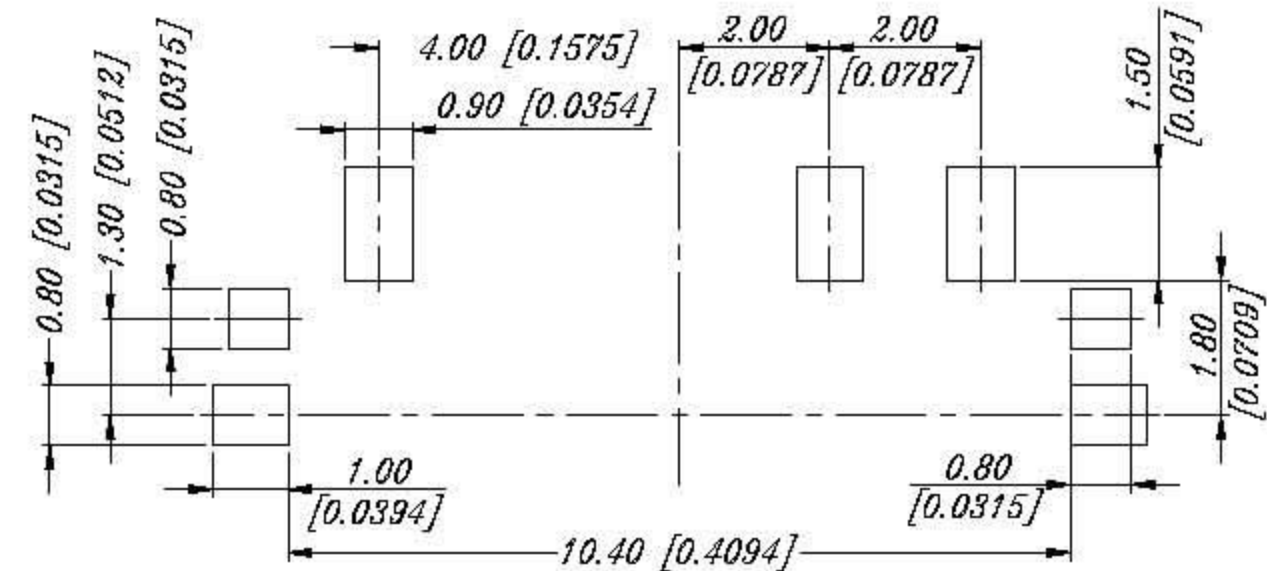
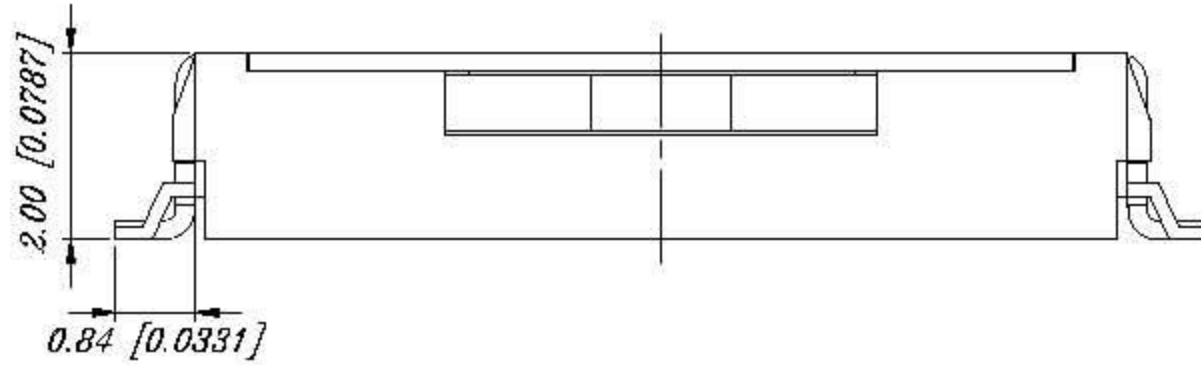
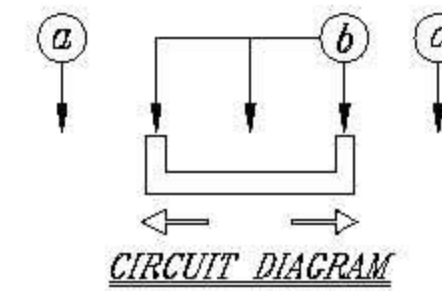

P.C.B LAYOUT

General Tolerance : ±0.2mm

S2S-AFC

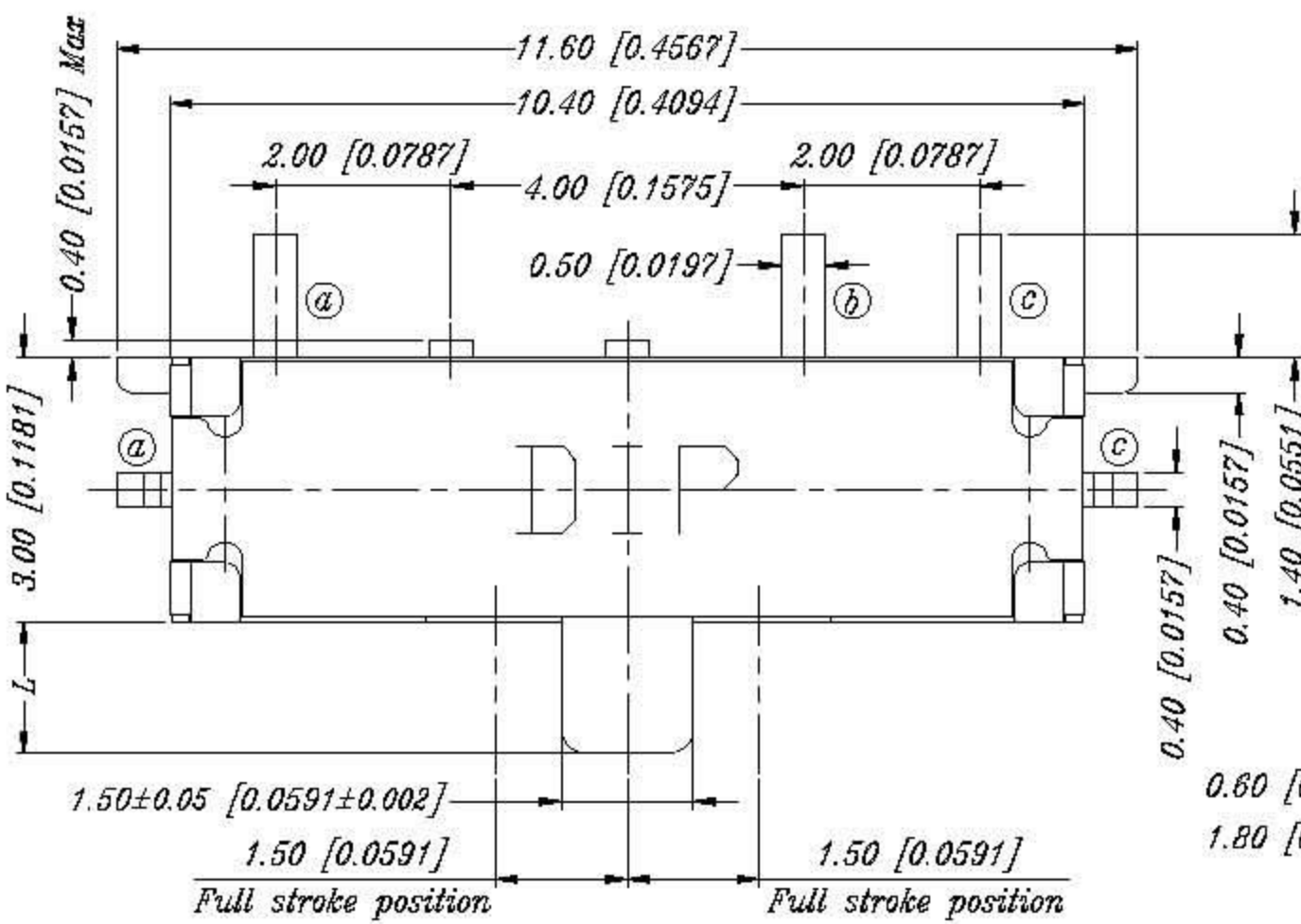

PART NO	L
S2S-A15FC	1.50 [0.0591]
S2S-A25FC	2.50 [0.0984]

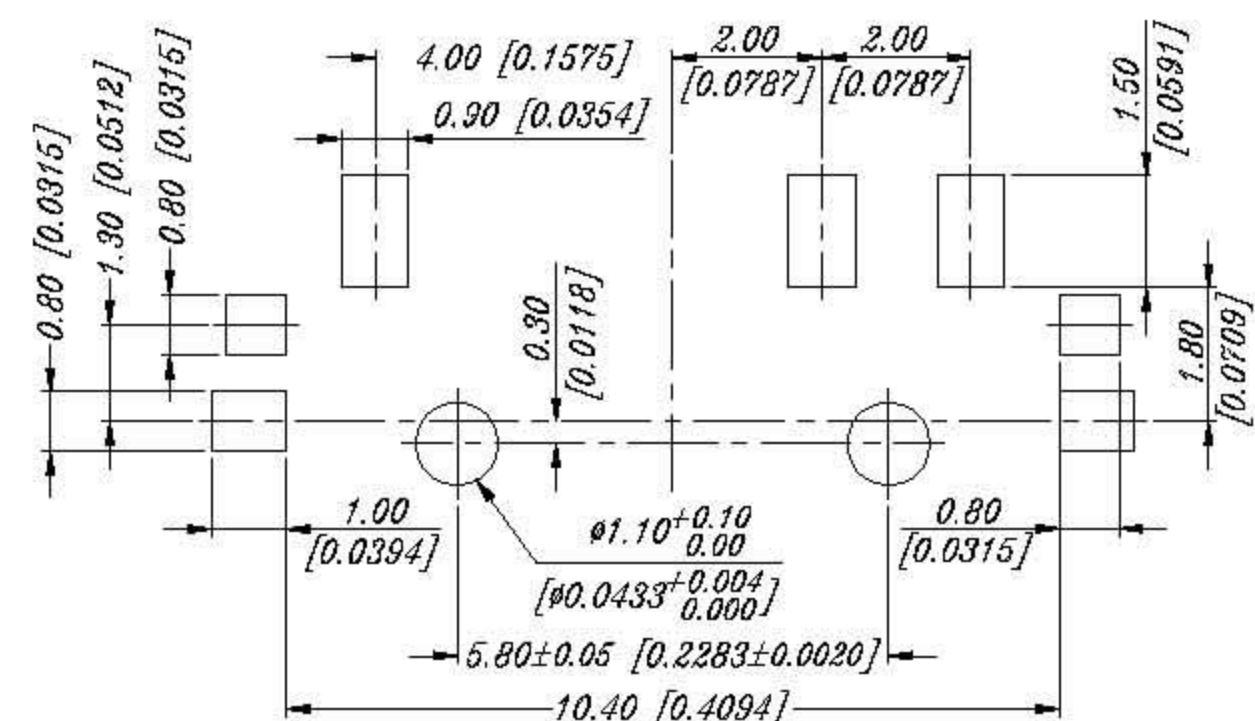
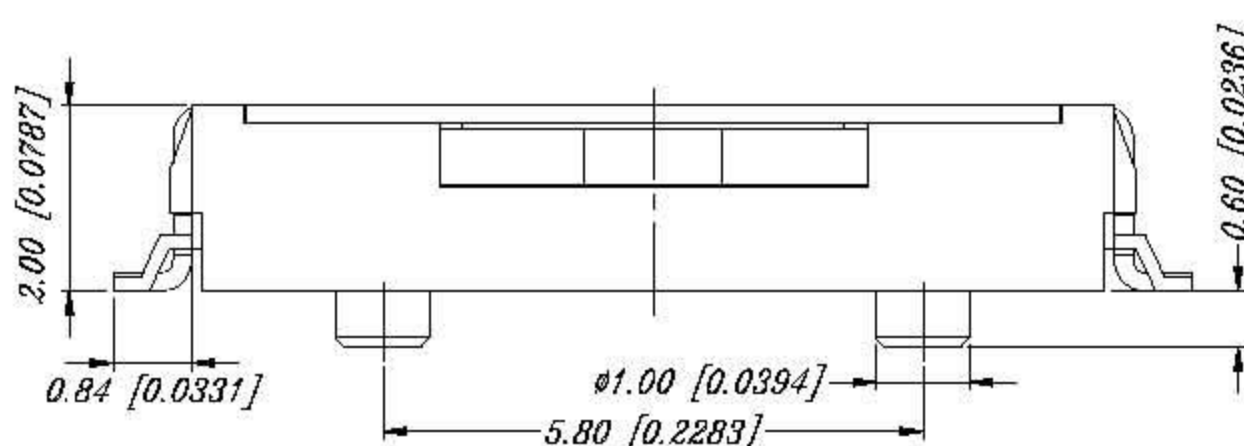
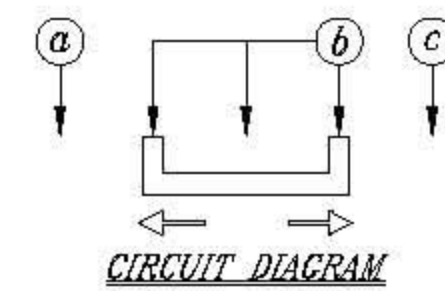

P.C.B LAYOUT

General Tolerance : ±0.2mm

DIMENSION

S2S-AL

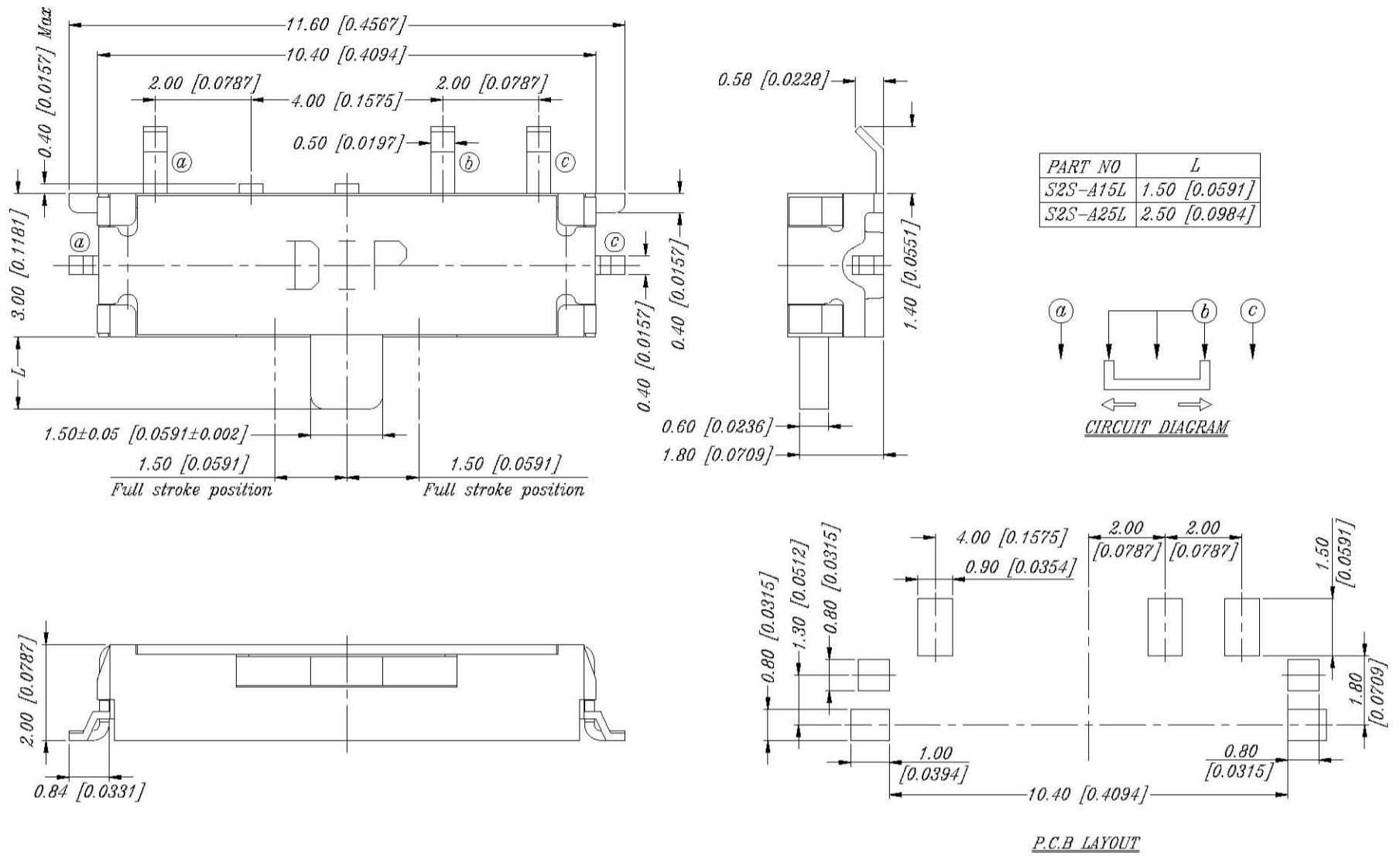

General Tolerance : $\pm 0.2\text{mm}$

S2S-ALC

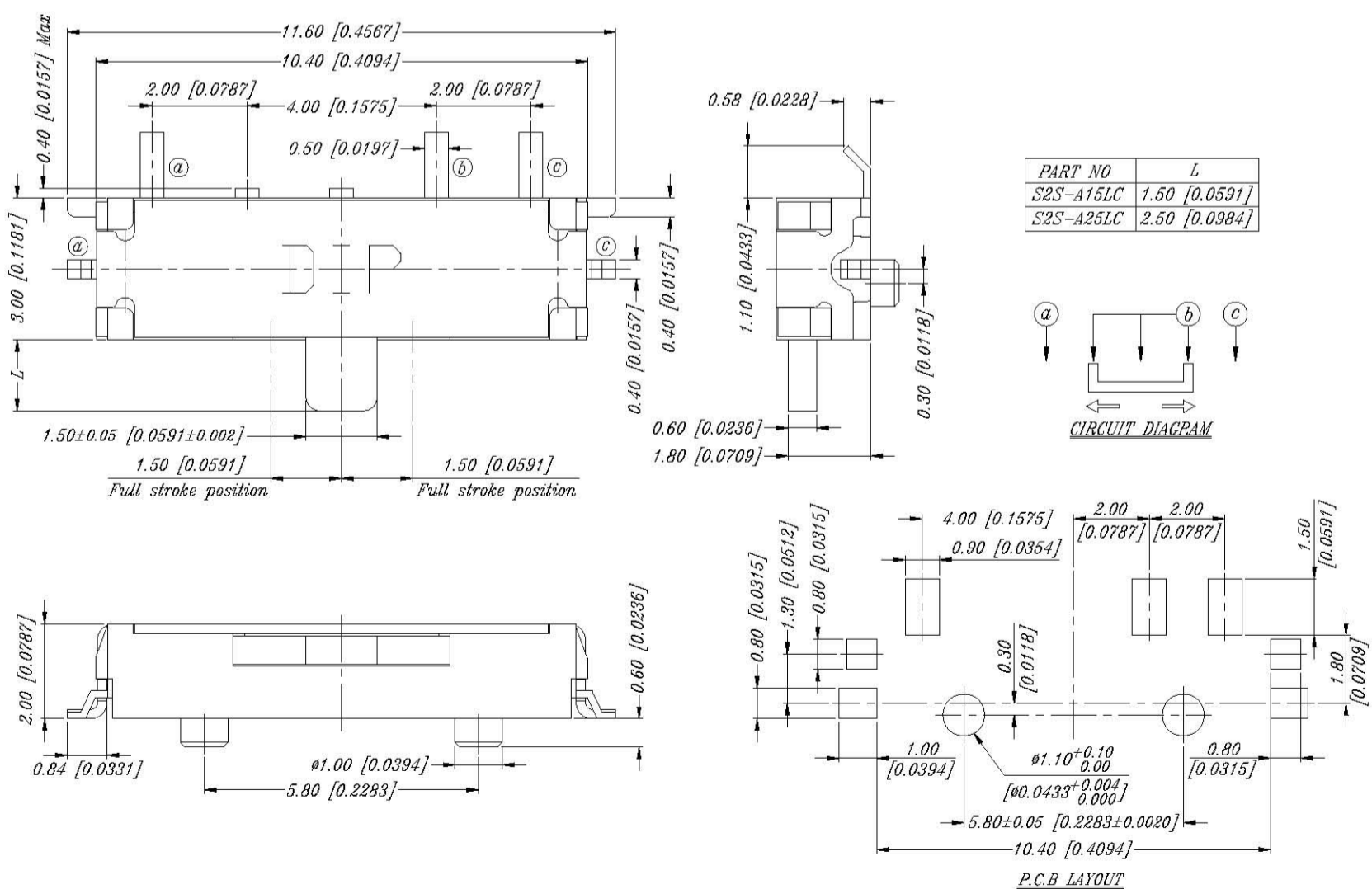

General Tolerance : $\pm 0.2\text{mm}$

DIMENSION

S2S-BF

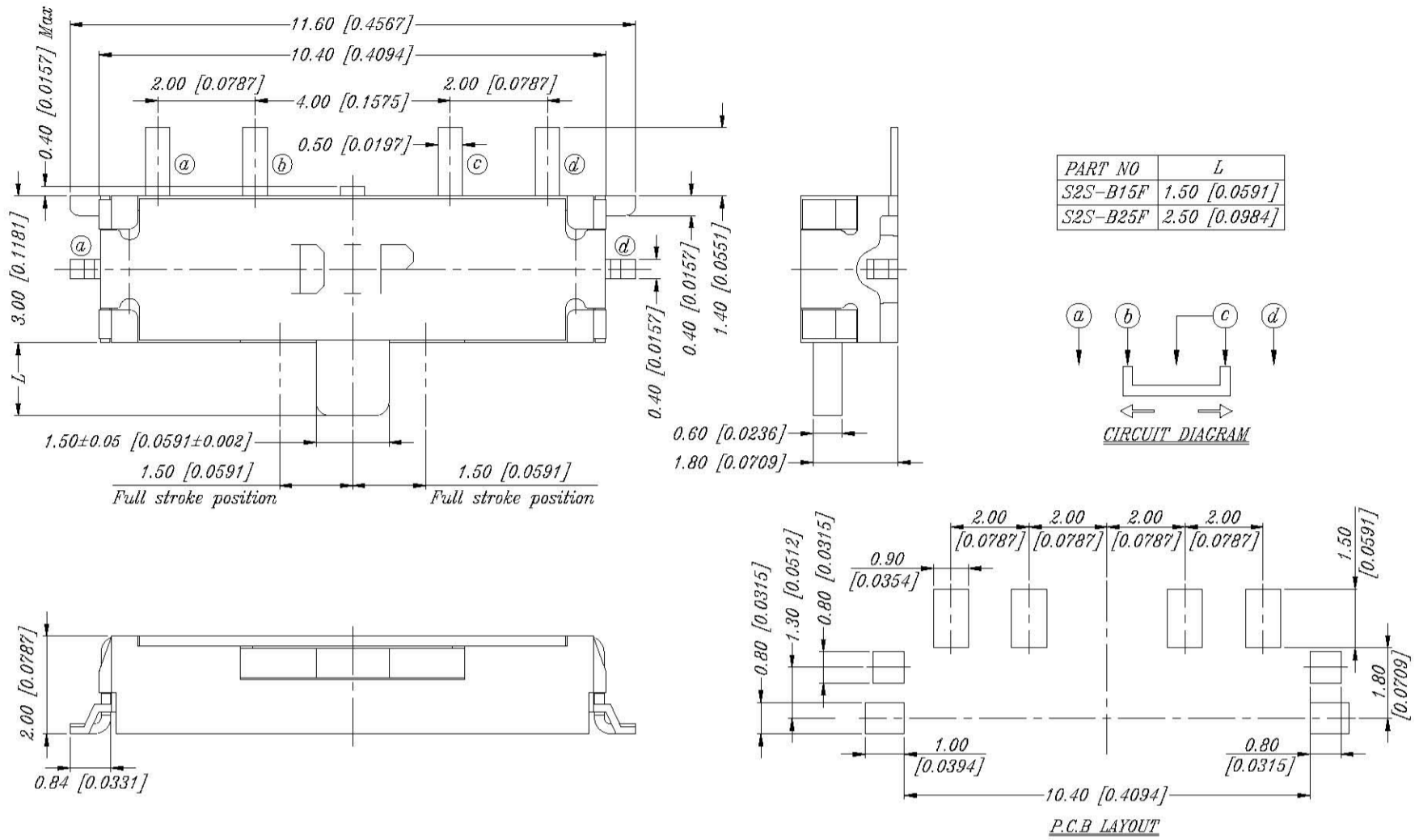

General Tolerance : ±0.2mm

S2S-BFC

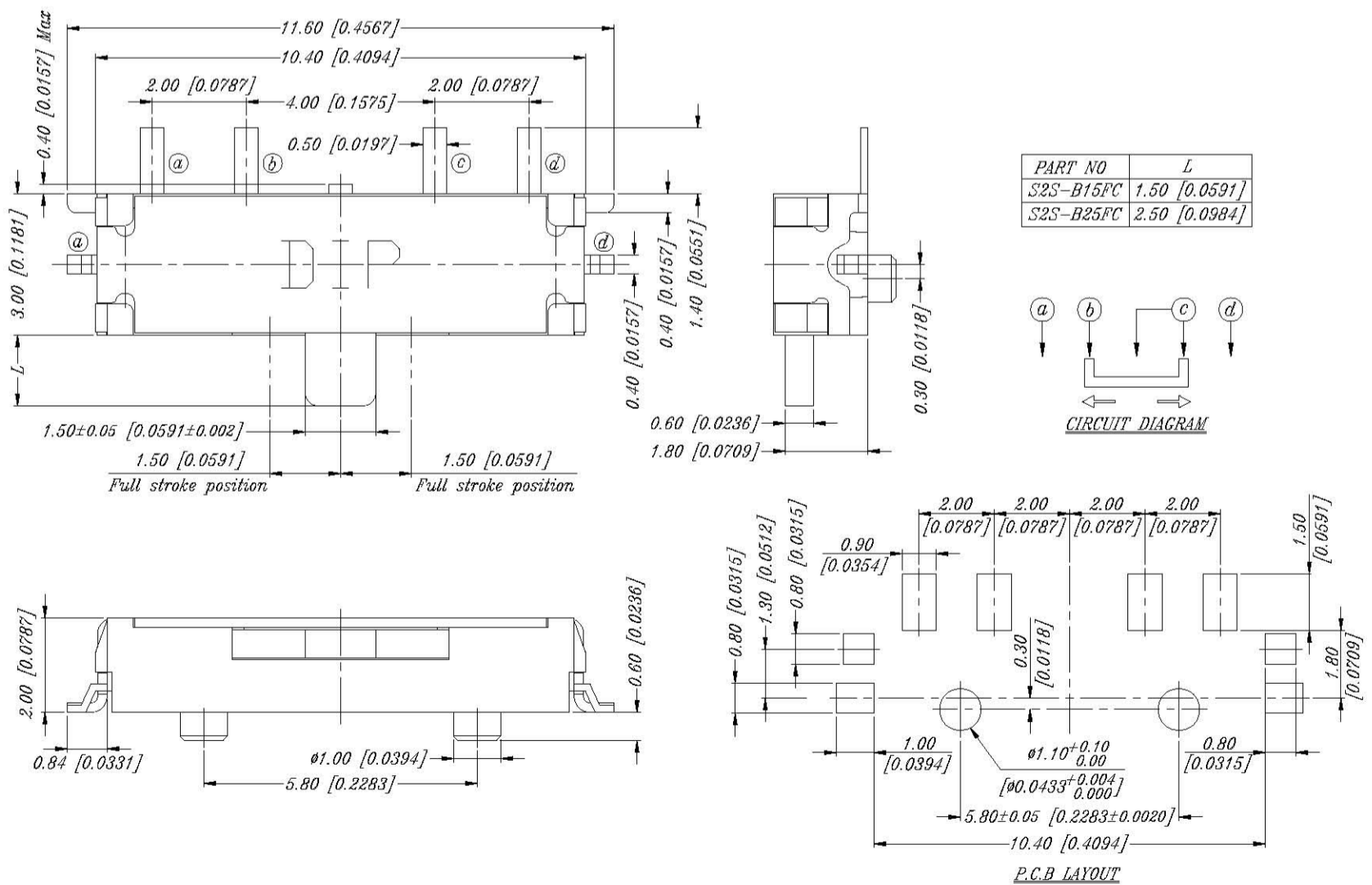

General Tolerance : ±0.2mm

DIMENSION

S2S-BL

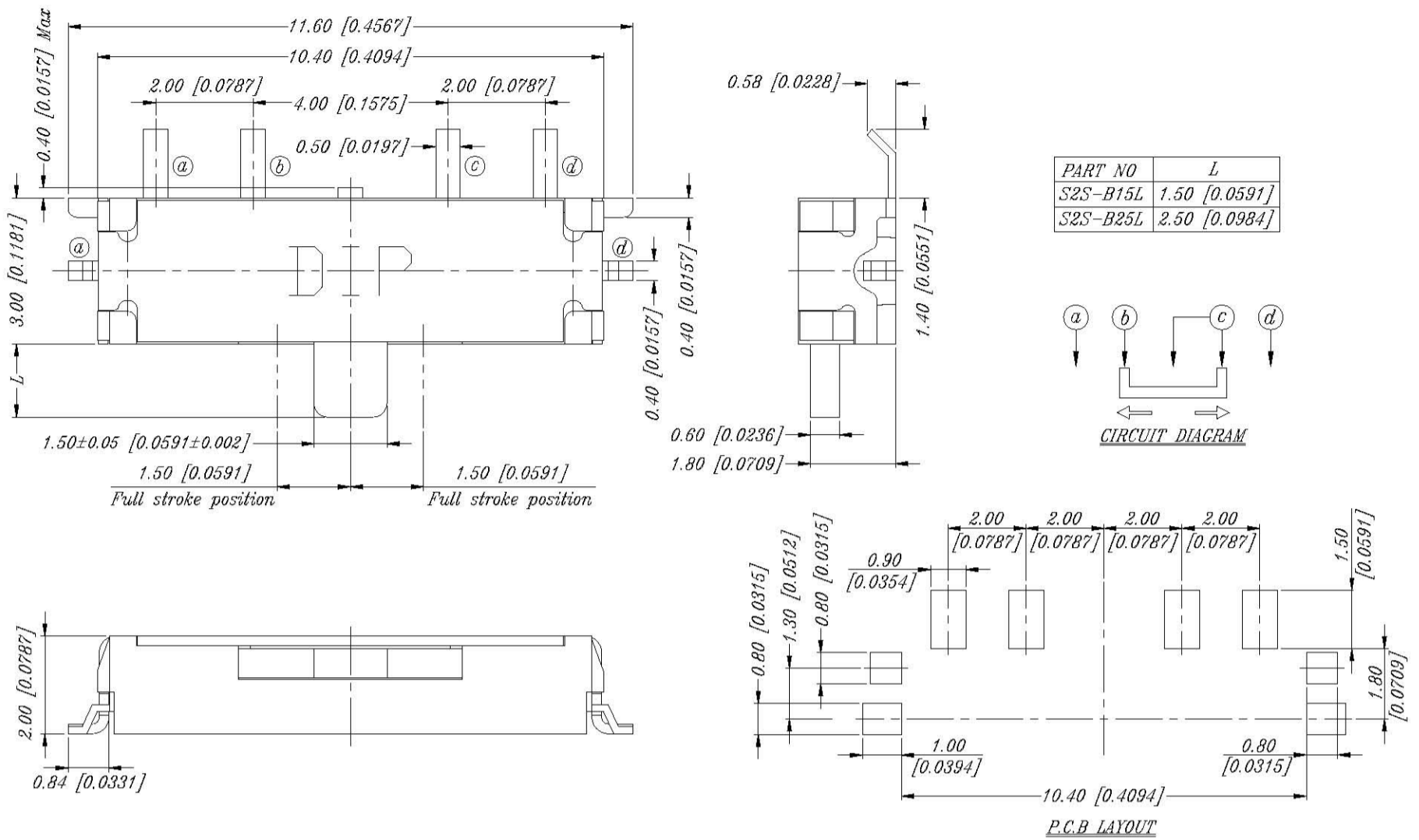

General Tolerance : $\pm 0.2\text{mm}$

S2S-BLC

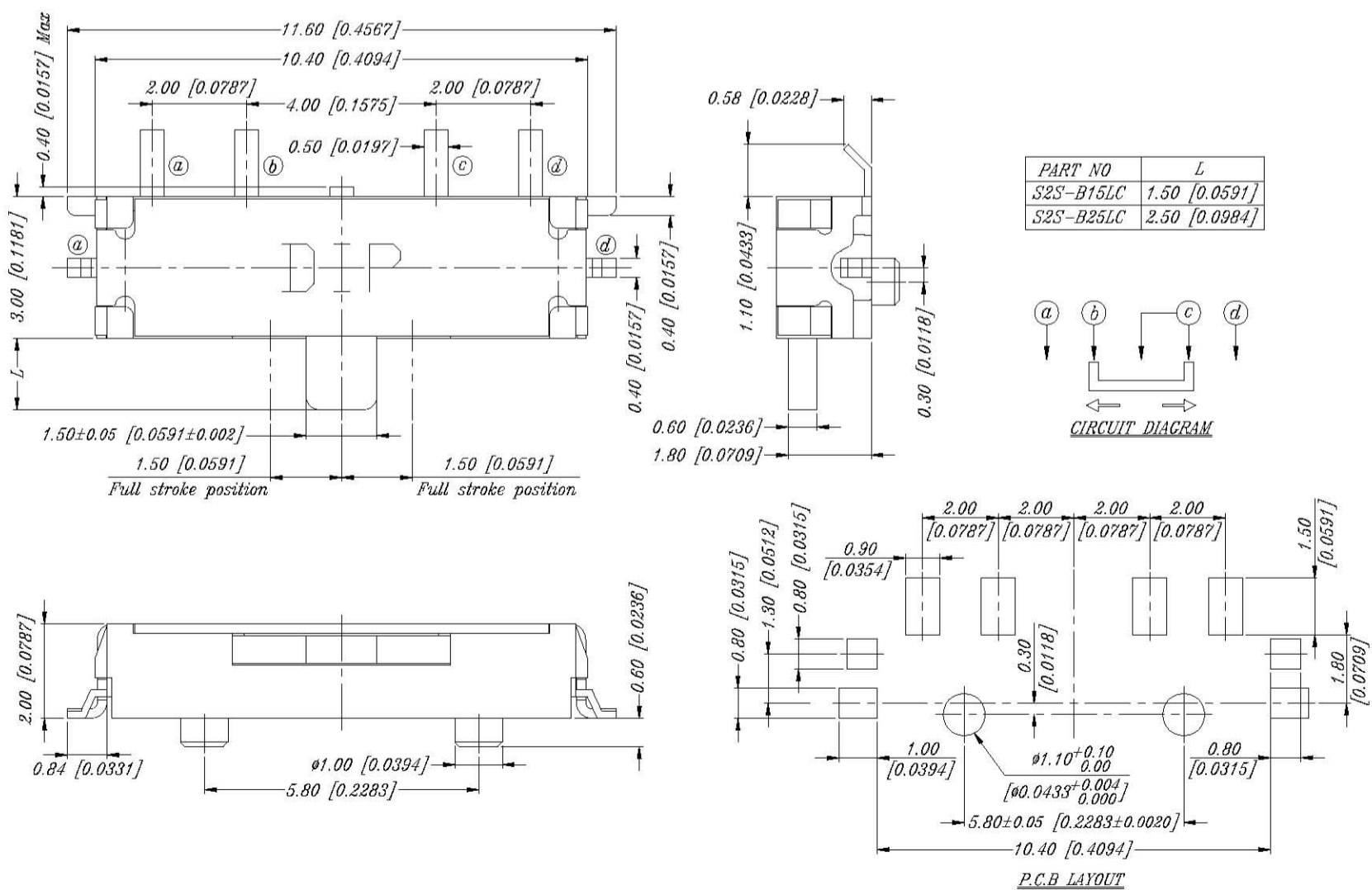

General Tolerance : $\pm 0.2\text{mm}$

HOW TO ORDER

S 2 S - □ □ □ □ □ - □

Package :
T/R = Tape & Reel

□ = Without Post
C = Post

Terminal Type :
L = J Bend
F = Flat

Stem Height :
15 = 1.5mm
25 = 2.5mm

Poles-Positions :
A = 1P2T
B = 1P3T

2S = Double-Side Recoil

S = Slide Switch

SPECIFICATION

△MECHANICAL

Operation Force : 100±50gf
Travel: 1.50±0.2mm
Operation Temperature Range:-30°C to +80°C
Storage Temperature Range:-40°C to +90°C

△ELECTRICAL

Electrical Life: 50,000 cycles
Non Switching Rating : 0.2mA, 5V DC
Switching Rating : 300mA, 4V DC
Contact Resistance : 70mΩ max
Insulation Resistance : 100MΩ min. at 250 VDC
Dielectric Strength : 100 VAC/1 minute
Circuit : 1P2T,1P3T

MATERIAL

△COVER : Nickel Silver
△CONTACT DISC : Alloy Copper, with gold cladding
△TERMINAL : Phosphor Bronze, with silver cladding
△BASE : UL94V-0 Nylon High-Temp Thermoplastic
Color : Black<1P2T>,Brown<1P3T>
△STEM : UL94V-0 Nylon High-Temp Thermoplastic
Color : Black

SOLDERING PROCESS

△HAND SOLDERING : Use a soldering iron of 30 watts, controlled at 350°C approximately 5 seconds while Applying solder.

△REFLOW SOLDERING : When applying reflow soldering, the peak temperature of the reflow oven should be set to 260°C max.

△Temperature Profile :

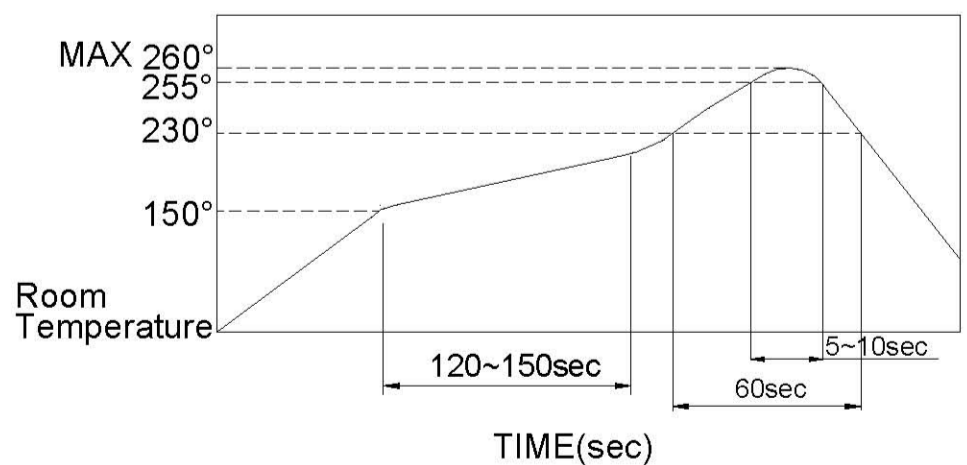

PACKING

REEL

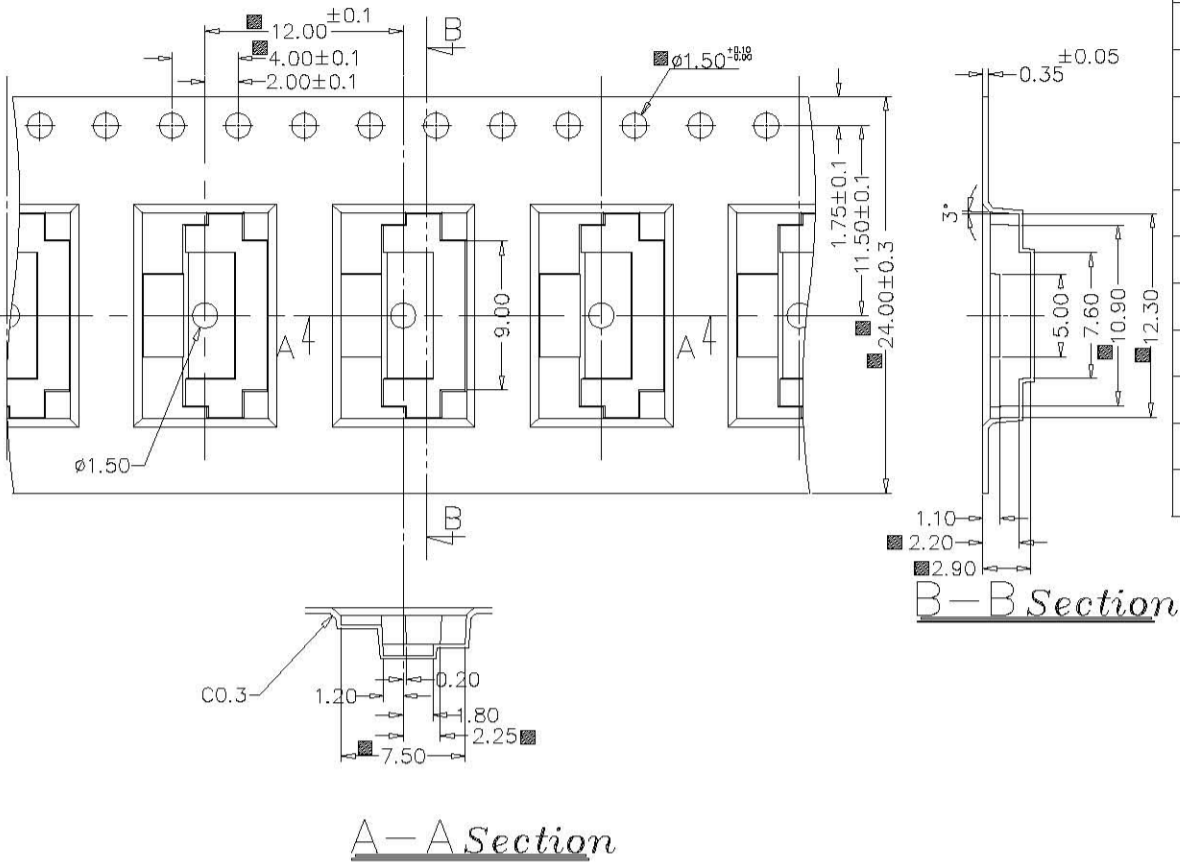

Part Number	Number Per Tube	Number Per Reel
S2S-15AF	-	2000
S2S-25AF	-	2000
S2S-15AFC	-	2000
S2S-25AFC	-	2000
S2S-15AL	-	2000
S2S-25AL	-	2000
S2S-15ALC	-	2000
S2S-25ALC	-	2000
S2S-15BF	-	2000
S2S-25BF	-	2000
S2S-15BFC	-	2000
S2S-25BFC	-	2000
S2S-15BL	-	2000
S2S-25BL	-	2000
S2S-15BLC	-	2000
S2S-25BLC	-	2000

General Tolerance : ± 0.1 mm